

THE SMART ENERGY STORAGE SYSTEM

WITH LITHIUM BATTERY AND INTEGRATED INVERTER/CHARGER

208/120V - THREE PHASE / 60HZ

MODEL
EP 30 / 75T



ENERPACK SERIES

STANDARD EQUIPMENT

- Digital control panel
- Distribution panel
- Canopy made of galvanized steel
- Lifting eyes
- Forklift guides



POWER SOURCES

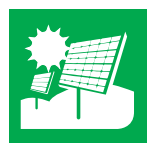

PHOTOVOLTAIC

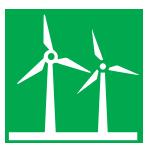

WIND ENERGY



POWER GENERATORS

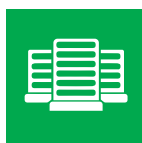

UPS

APPLICATIONS



CONSTRUCTION



DISASTER RELIEF



EVENTS

TecnoGen USA
POWER GENERATORS

www.tecnogenusa.com

FTG
EQUIPMENT SOLUTIONS

ENERPACK

208/120V - THREE/MONO-PHASE / 60Hz

GENERAL TECHNICAL DATA	Units	EP 30 / 75T
Rated Voltage	VAC	208
Frequency	Hz	60
Nominal Energy Storage	kWh	72,15
Continuous load at power factor = 0,8	kVA	30
Peak power 1 min. @25 °C	kW	36
Communication technology		CAN bus
Sound Power Level	dB(A)	Zero Noise
Protection degree		IP44

BATTERY		PJO-48-500-TDS
Battery Voltage	VDC	48
Brand		archimede energia
Manufacturing country		ITALY
Quantity	units	3
Lithium cell chemistry		LiNMC
Discharged current		0,5 C
DOD % (depth of discharge @25°C ±2)		80%
Working life cycle (80% DoD)		> 6000

INVERTER		
Quantity	units	3
Continuous output power	kVA	10
Operation Temperature	°C / F	-20 to +45 * / -4 to 113*

PERFORMANCES		
EXAMPLE OF PERFORMANCE IN BATTERY MODE WITH CONSTANT LOAD:		
Load 3 kW	time	18 h : 28 min
Load 5 kW	time	11 h : 05 min
Load 10 kW	time	5 h : 32 min
Load 30 kW	time	1 h : 51 min
Recharging time (@ 80% DoD) @ 50 kW	time	4 h : 00 min

CONTROL		
Energy Management system		Digital
Battery management system (BMS)		Hermes M3
Brand		archimede energia
Manufacturing country		ITALY

DISTRIBUTION PANEL		
INLET connection		1 Row of Camlocks
		1 Row of camlocks 2 socket 120 V 100A
OUTLET connections		3 Receptable 120V 20A 2 Twist Lock 120/208V 30A 1 Twist lock 120 30A

DIMENSIONS AND WEIGHT		
Dimensions (L x W x H)	mm / inch	2294x1134x2193 90,30x 44,6x 86,3
Weight	kg / lbs	1970 / 4343

OPTIONS		
INLET Powerlocks		1 row on request
Sockets		on request
Solar Battery Charger		on request
Recharger for electric cars		on request

PJO-48-500-TDS

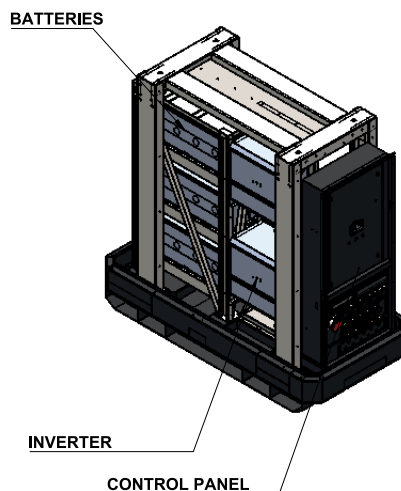
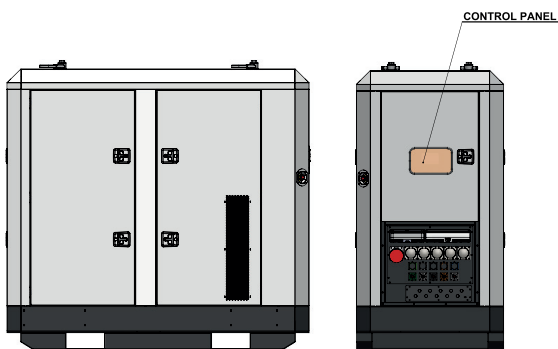

MODEL
EP30/75T

ENERPACK SERIES

* for temperatures > 45 ° C /113 F customized equipment is available as option

Technical data not binding